

Operators and Maintenance Manual

Display EEM MOT 01 FL01.01



Rev. 01 – October 2017

Copyright:

Auto & Aero Technologies Sp. z o.o.
Mazowiecka 10/5, 20-723 Lublin, Poland
■ email: info@aatech.pl ■ www.aatech.pl



Display EEM MOT 01 FL01.01

Table of Contents

Introduction	3
1. General information.....	3
2. Handling in transport and storage	4
3. Installation.....	5
3.1. Environmental specifications.....	5
3.2. Dimensions.....	5
3.3. Mounting.....	6
3.4. Power and wiring.....	6
4. Operation and maintenance.....	8
5. Service, diagnostics and repairs.....	11
5.1. Service life	11
5.2. Checks	11
5.3. Cleaning and conservation	12
5.4. Troubleshooting.....	12
5.5. Repairs	13
5.6. Re-programming.....	13
5.7. Spare parts	13
6. Warranty	13

Copyright:

Display EEM MOT 01 FL01.01

Introduction

This instrument is intended for ultralight, microlight, homebuilt and experimental aircraft. The purpose of EEM MOT 01 type display is to present key flight information to the pilot. Version FL01.01 displays air speed of the aircraft.

The device is equipped with an in-built colour display protected by anti-reflective coated glass. The encoder knob & push-button located in the front provides user interaction with the device. The electric connector, hardware and software identification plates are located in the back of the casing (Fig. 1)

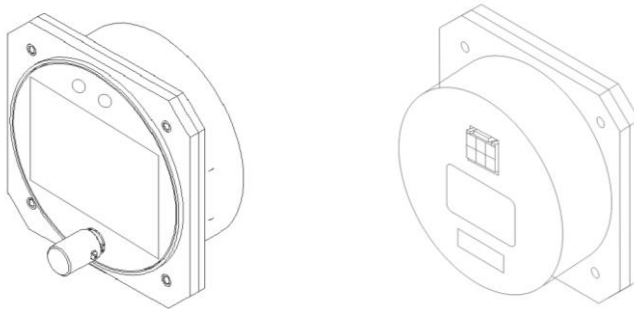

Fig. 1. EEM MOT 01 Display

This instrument is not certified by the FAA and EASA. Fitting of this instrument to certified aircraft is subject to the rules and conditions pertaining to such in your country. Please check with your local aviation authorities if in doubt.

1. General information

This manual contains binding information, guidelines and warnings for safe handling and maintenance of this particular instrument before installation,

Copyright:

Display EEM MOT 01 FL01.01

during installation and in its operating phase. This document does not contain rules and guidelines on operation of aircraft instruments at large.

Read the manual thoroughly before turning on the instrument and precisely follow the instructions to install and configure it. This manual does not replace instructions on installation, maintenance and operation of this device in a particular airframe - these are to be prepared by the user. Instructing the pilots and maintenance personnel on operation of the instrument is also the responsibility of the user.

Operation of this instrument is the sole responsibility of the pilot in command (PIC) of the aircraft. This person must be proficient and carry a valid and relevant pilot's license. This person has to make themselves familiar with the operation of this instrument and the effect of any possible failure or malfunction. Under no circumstances does the manufacturer condone usage of this instrument for IFR flights.

This manual defines the scope of maintenance measures the user is authorised to conduct on their own. Any repairs or modifications outside this scope conducted by the user or contracted to a third party, as well as using non-original parts and subassemblies voids the warranty, relieves the supplier from any liability, making the instrument lose the status of the product of Auto & Aero Technologies Sp. z o.o. with all the resulting consequences.

2. Handling in transport and storage

1. The EEM MOT 01 monitor is bubble-wrapped to protect it against vibration and other physical damage, and packed in a cardboard box together with the warranty card.
2. The display must be stored and transported assuring that:
 - the ambient temperature stays in the range of 10 ÷ 40°C
 - the ambient relative humidity stays in the range of 10÷90 %, safe from condensation.
3. The display should be protected from water.

Copyright:

Display EEM MOT 01 FL01.01

3. Installation

3.1. Environmental specifications

The EEM MOT 01 display has been designed to be installed in non-hermetic cockpits of ultralight aircrafts of ceiling not exceeding 3 000 m (10 000 ft). Acceptable range of operating parameters is listed below:

- Operating temperature: $-20^{\circ}\text{C} \div 50^{\circ}\text{C}$
- Short-term operating temperature: $-25^{\circ}\text{C} \div 60^{\circ}\text{C}$
- Humidity: $0 \div 95\%$, no condensation;
- Ambient air pressure: $45 \div 105\text{ kPa}$;
- Vibrations: $<5\text{ g}$ at frequencies below 150 Hz;

3.2. Dimensions

Outline dimensions of the display are: 85 x 85 x 67 mm (*width x height x depth*), Weight: 175 g.

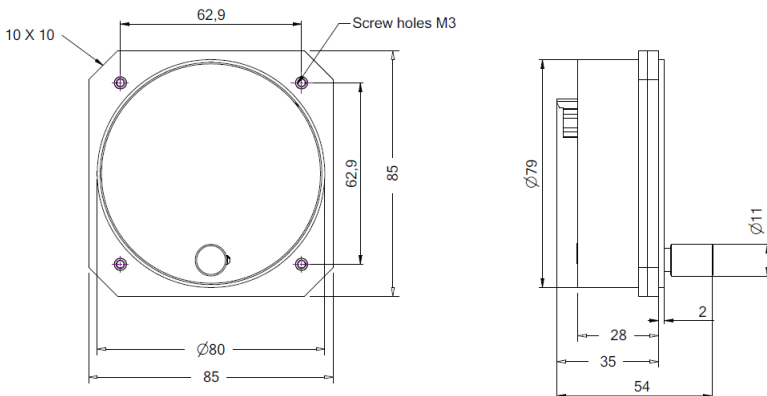

Fig. 2. EEM MOT 01 Display outline drawing

Copyright:

Display EEM MOT 01 FL01.01

3.3. Mounting

The display should be located conveniently within the pilot's view in the control panel in the cockpit. The diameter of the mounting hole to be cut in the panel is 80mm. It is recommended that the display is installed from the rear side the control panel. The display is to be fastened to the panel by means of four M3 screws that are located symmetrically to the centre of the mounting hole in the spacing of 62.9 mm (Fig. 3).

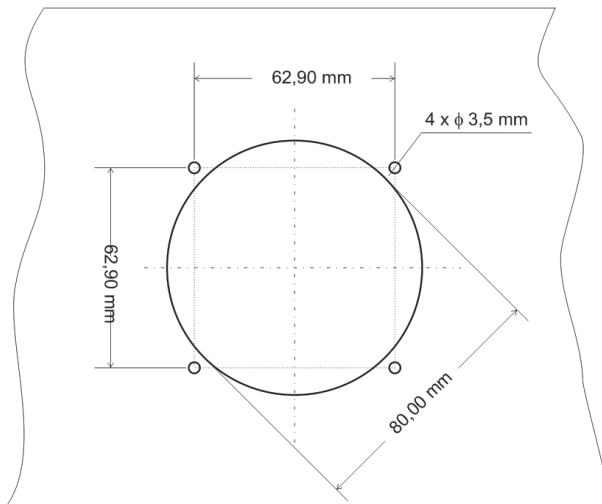

Fig. 3. Mounting hole and screw holes measurements (not to scale)

3.4. Power and wiring

The EEM MOT 01 display is powered from the aircraft power system. Power specifications: nominal supply voltage 12V, acceptable supply voltage range 8 ÷ 30V, current < 85mA.

Copyright:

Auto & Aero Technologies Sp. z o.o.
Mazowiecka 10/5, 20-723 Lublin, Poland
■ email: info@aatech.pl ■ www.aatech.pl

Display EEM MOT 01 FL01.01

The EEM MOT 01 display is connected to the system by in-built MOLEX Ultra-Fit 3.5 mm 6 pin male connector located at the back of the instrument. A schematic diagram of the connection is shown in Figure 4 and in Table 1.

The power supply (pins no. 5 and 6) requires 0.5 mm² wires.

Data bus (pins no. 3 and 4) requires twisted pair wires (2 x 0.5mm²) according to DIN VDE 0814 (Fig. 4). Twisting should continue to the pins of the connector.

Pins 1 and 2 are to be left unconnected.

Tab. 1. Connector pin assingment and pin insertion view

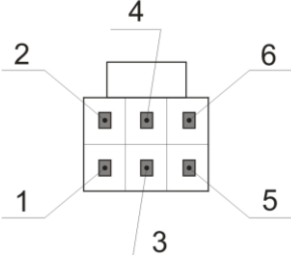
Pin number	Function	Connector schematic
1	Reserved (do not connect)	
2	Reserved (do not connect)	
3	RS A	
4	RS B	
5	GND	
6	+12 V	

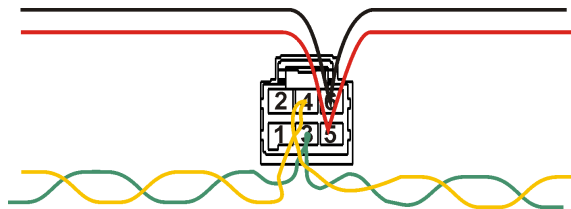

Fig. 4. Wire twisting and connection

Copyright:

Display EEM MOT 01 FL01.01

4. Operation and maintenance

The display is to be connected to AUX AVS 2.

The front panel of EEM MOT 01 is composed of three elements: the display, two status diodes (alert indication), and the encoder knob & push-button for setting parameters (Fig. 5).

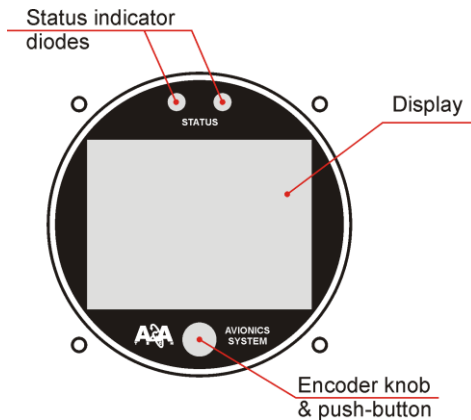

Fig. 5. Front panel of EEM MOT 01 Display

The EEM MOT 01 display displays values of flight parameters that are either directly measured or calculated by the system. The display starts automatically as the power is turned on.

As shown in Figure 6, the monitor with FL01.01 software version presents:

- a) Air speed of the aircraft.

Copyright:

Display EEM MOT 01 FL01.01



Fig. 6. Display of the FL01.01 software version

On client’s request, warning and alarm threshold values may be set for some of the above parameters according to the specification provided by the aircraft supplier. Default threshold values are listed in Table 2.

Tab. 2. Parameters displayed by EEM MOT 01 FL01.01 display

Lp.	Parameter	Symbol/ name in display	Unit	Range of bar graph indicator	Warning/alarm thresholds	
					Warning	Alarm
1	Air speed of the aircraft	AIR SPEED	km/h	0 – 200 km/h	under 60 km/h from 160 to 180 km/h	above 180 km/h

As the aircraft operates within “normal” range of the parameter in question, the instrument displays values in green, and status diodes are green. If the threshold level is being exceeded, the instrument informs the pilot by changing both the colour of displayed figures and the colour of status diodes. Exceeding the alarm threshold is additionally indicated by the diodes flashing red. The pilot can switch off flashing by pushing the encoder knob. Figure 7 presents the idea of colour codes and warning/alarm indication.

Copyright:

Display EEM MOT 01 FL01.01



Fig. 7. The idea of flight parameter status information

Thus, information on the status of a flight parameter is presented in two ways:

- 1) by means of the colour of two status diodes according to the following colour code:
 - a) **green** – flight parameters within normal range;
 - b) **orange** – warning;

Copyright:

Auto & Aero Technologies Sp. z o.o.
Mazowiecka 10/5, 20-723 Lublin, Poland
■ email: info@aatech.pl ■ www.aatech.pl

Display EEM MOT 01 FL01.01

- c) **red** – alarm;
- 2) by means of the colour of digits and bar graph (if applicable) presenting the value of the parameter:
- a. **green** – flight parameters within normal range;
 - b. **orange** – warning;
 - c. **red** – alarm;

The status information is obtained as a result of analysis conducted by the instrument on the basis of digital input transmitted by the measurement modules of the system.

Both diodes are always of the same colour corresponding to the status of the parameter that assumes “the worst” value.

5. Service, diagnostics and repairs

5.1. Service life

- a) TBO of the display is not defined.
- b) In the case of failure or error, the display must not be used any more.

5.2. Checks

The following checks are recommended:

- 1) At pre-flight check:
 - a. Turn on the power to check if operational;
- 2) After 100 hours of flight:
 - a. Check the instrument’s electric connections;
 - b. Turn on the power on to check if operational.

Copyright:

5.3. Cleaning and conservation

The screen is to be buffed with water-damped soft cloth. Optionally, if very dirty, can be cleaned with cloth sparingly damped with mild soap solution or with a liquid dedicated for liquid crystal displays. Caution: the surface is vulnerable to scratching.

5.4. Troubleshooting

- a) If the screen stays blank when power is applied, turn off power supply and verify power connection. Ensure that your power supply is capable of supplying at least 8 volts, and no more than 30 V.
- b) If no information is displayed when power is applied (Fig. 8), check connection to measurement modules.



Fig. 8. Indication of no connection to measurement modules

- c) In the case of the instrument's failure or malfunction, turn power off and on again.
- d) If the above does not solve the problem, the display needs to be replaced.
- e) A defective instrument must not be used.

Copyright:

**Display EEM MOT 01 FL01.01****5.5. Repairs**

Repairs and inspections of the instrument can be conducted only by its manufacturer.

The display does not contain any user-serviceable parts. Unauthorized repairs or modifications may result in permanent damage to the equipment and void the warranty.

If the monitor fails, return the device to the Manufacturer with description of the failure circumstances and symptoms.

5.6. Re-programming

Modifications to the instrument's settings that are not possible to be conducted by means of the encoder can be introduced by means of service software provided by the Manufacturer and the dedicated diagnostic interface.

The instrument's firmware updates are to be conducted on the basis of the bulletins published by the Manufacturer. The updates can be introduced by means of service software provided by the Manufacturer and the dedicated diagnostic interface.

5.7. Spare parts

The instrument does not contain any user-serviceable parts. The user is not allowed to disassemble it nor replace any subassemblies.

6. Warranty

1. Auto & Aero Technologies Sp. z o.o. warrants this product to be free from defects in materials and workmanship.
2. Auto & Aero Technologies Sp. z o.o. warrants proper operation of the product if it is used in accordance with its intended purpose and in accordance with the Operators and Maintenance Manual.

Copyright:

Auto & Aero Technologies Sp. z o.o.
Mazowiecka 10/5, 20-723 Lublin, Poland
■ email: info@aatech.pl ■ www.aatech.pl

Display EEM MOT 01 FL01.01

3. Auto & Aero Technologies Sp. z o.o. warrants this product for 12 months from date of purchase.
4. Auto & Aero Technologies Sp. z o.o. will, at its sole option, repair or replace any components that fail in normal use. Such repairs or replacement will be made at no charge to the customer for parts or labour. The customer is, however, responsible for any transportation cost. The repair or replacement will be completed within 30 days from delivery of the product to Auto & Aero Technologies Sp. z o.o. However, if the failure is possible to be eliminated by means of updating the product's firmware, and if Auto & Aero Technologies Sp. z o.o. provides the customer with appropriate service tools, the Customer will conduct firmware update by themselves.
5. Any warranty repair will extend the warranty for the time of the repair.
6. If a valid warranty claim is lodged within months 7 to 12 after date of purchase, the warranty extends for a further 6 months after completion of the warranty repair.
7. This warranty does not cover failures due to:
 - a) mechanical damages and damages resulting from them,
 - b) unauthorised repairs,
 - c) damage caused by abuse or misuse,
 - d) unauthorised alterations to hardware or software.
8. The warranty does not cover claims that arise from the product parameters unless they are different from values declared by Auto & Aero Technologies Sp. z o.o.
9. The warranty does not cover activities that belong to normal operation such as cleaning and conservation, operation checks, and periodic inspections according to the Operators and Maintenance Manual.
10. The Customer loses all rights arising from the warranty if the product's protective seals are found to be tampered with.
11. The rejection of Auto & Aero Technologies Sp. z o.o. to conduct a warranty repair voids the warranty.

Copyright:



Display EEM MOT 01 FL01.01

The information in this document is subject to change without notice and should not be construed as commitment by Auto & Aero Technologies Sp. z o.o.

These technical data and the information embodied therein are the property of Auto & Aero Technologies Sp. z o.o., and shall not, without prior written permission of Auto & Aero Technologies Sp. z o.o., be disclosed in whole or in part to third parties. This statement shall be included on any reproduction of these data, in whole or in part. The Manual must remain with the engine/aircraft in case of sale.

Copyright 2017 © - all rights reserved.

Other product names in this documentation are used purely for ease of identification and may be trademarks of the respective company or owner.

Approval of translation has been done to best knowledge and judgement - in any case the original text in English language is authoritative.

Copyright:

Auto & Aero Technologies Sp. z o.o.
Mazowiecka 10/5, 20-723 Lublin, Poland
■ email: info@aatech.pl ■ www.aatech.pl